

6

5

4

3

2

1

MATERIAL AND FINISH:

Front flange: Polycarbonate, black,
 UL-94V-0 rated
 Body: Nylon, black, UL-94V-0 rated
 Cap: Glass filled Nylon, UL-94-HB rated
 Contact: Brass, Nickel plated
 End plate: S.R.B.F
 End plate support: Steel, Nickel plated
 Spring: Spring Steel

ENVIRONMENTAL

Operating temperature: -30°C to +70°C

**RoHS
COMPLIANT**

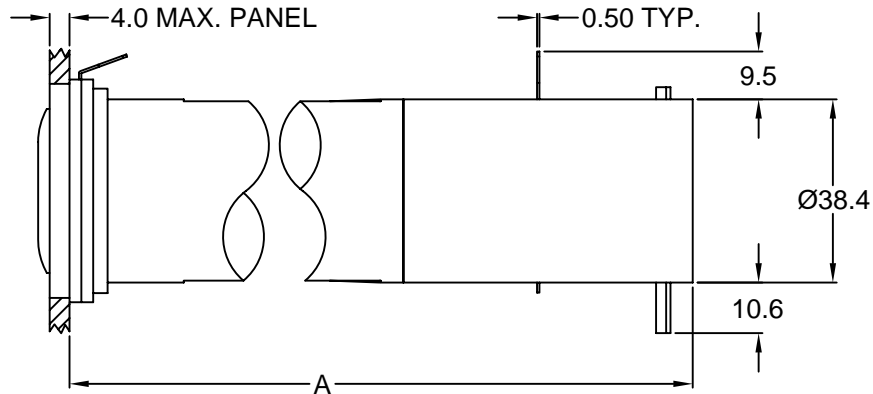
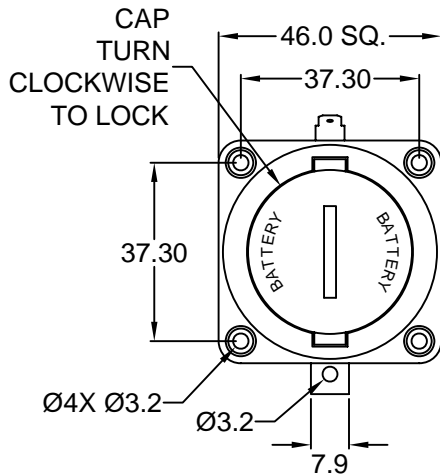
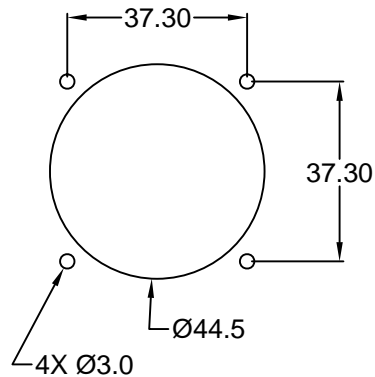
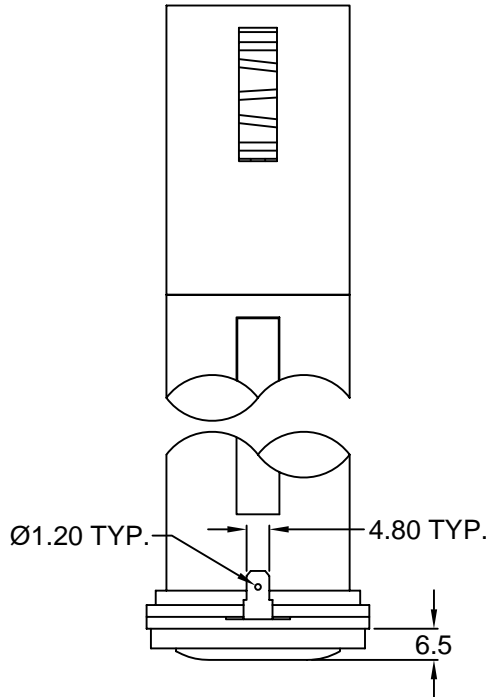

P/N	A±1.0
B16 (1 CELL)	83.0
B17 (2 CELLS)	143.5
B18 (3 CELLS)	204.0
B19 (4 CELLS)	264.5
B20 (5 CELLS)	324.5

TOLERANCE UNLESS OTHERWISE SPECIFIED	
X	± 1
X.X	± 0.4
X.XX	± 0.20

DRAWN BY	TD	DATE:	08/20/99
CHECK BY		DATE:	
APPR BY	SS	DATE:	10/20/99

Power Dynamics, Inc.
 Phone: 973 560-0019 Whippany, New Jersey Fax: 973 560-0076

**PART: D (R20) BATTERY HOLDER,
 PANEL MOUNT**

PART #:	B1X	SHEET	1 of 1
SIZE:	A	ALL DIMENSIONS FOR REFERENCE ONLY	REV: C
SCALE:	NTS	DIMENSIONS ARE IN MILLIMETERS	

REV	DATE	CHANGE	CHNG CHECK APPR			
			SS	TD	PB	PB
A	12/20/00	REVISED AND REDRAWN	SS	TD		
B	8/15/01	ADD MOUNTING HOLE DIM.	PB	TD		
C	03/18/02	REVISED / UPDATED	GO	TD		

D

C

B

A